



EZ3005sc Online ISE Chloride Analysis for Clean Water

Applications

- Drinking Water
- Surface Water



The Challenge of Consistent Chloride Monitoring

Accurate chloride monitoring in municipal and industrial water is often affected by fouling, drift, and temperature variability, increasing compliance risk and operator workload. The EZ3005sc Chloride Analyzer uses discontinuous ISE analysis with temperature controlled measurement to deliver stable, precise results. Automated operation minimizes reagent consumption and maintenance, helping operators maintain reliable chloride data, reduce downtime, and ensure confident process control and regulatory compliance.

Reliable, Stable Measurements

Avoid downtime from unreliable ISE data caused by temperature fluctuations. The EZ3005sc stabilizes both sample and electrode using a temperature controlled flow cell, eliminating measurement errors and delivering precise, repeatable chloride results operators can trust.

Lower Maintenance Effort

Minimize downtime and service costs with the EZ3005sc. Automated 2 point calibration, reagent alerts, a rugged ISE electrode, and minimal moving parts extend maintenance intervals; so operators spend less time servicing instruments and more time on plant operations.

Reduced Operating Cost

The EZ3005sc helps optimize operating costs by reducing chemical consumption and service visits. Multi stream capability monitors up to eight sample lines, lowering cost per sampling point and extending equipment life.

Designed for easy integration into existing control systems

With a wide range of analogue and digital outputs, this analyzer aligns with plant specific requirements, ensuring compatibility with existing infrastructure and immediate access to real time measurement data.

Technical Data*

Model	EZ3005sc
Parameter	Chloride
Range	2 - 100 mg/L Cl ⁻ 5 - 250 mg/L Cl ⁻ 10 - 500 mg/L Cl ⁻ 20 - 1000 mg/L Cl ⁻
Lower Limit of Detection (LOD)	2 - 100 mg/L Cl ⁻ : 2 mg/L 5 - 250 mg/L Cl ⁻ : 5 mg/L 10 - 500 mg/L Cl ⁻ : 10 mg/L 20 - 1000 mg/L Cl ⁻ : 20 mg/L
Precision	Better than 2% full scale range for standard test solutions
Measurement Method	Discontinuous, direct measurement by combined Ion-Selective Electrode
Cycle Time	Default: 5 minutes Continuous: 5 minutes
Sample Temperature	50 - 86 °F (10 - 30 °C)
Sample Quality	Maximum particle size 100 µm, < 0.1 g/L; Turbidity < 50 NTU
Interferences	Bromide [(Br)-], sulphide [(S) ²⁻], iodide [(I)-], cyanide [(CN)-] ions may interfere. Mercury [(Hg)+] must be absent. Ammonia [NH ₃] and thiosulphate [(S ₂ O ₃) ²⁻] may interfere. Fats, oil, proteins, surfactants and tar.
Reagent Requirements	Keep between 50 - 86 °F (10 - 30 °C)
Demineralized Water	Does not apply
Automatic cleaning	Yes; Frequency freely programmable: 6 hours, 12 hours, daily, weekly
Calibration	Automatic; 2-point; Frequency freely programmable: 6 hours, 12 hours, daily, weekly. Note: manufacturer recommends that a calibration is done when the reagents are replaced
Validation	Automatic; Frequency freely programmable: 6 hours, 12 hours, daily, weekly
Ambient Temperature	50 - 86 °F (10 - 30 °C) ± 4 °C deviation at 5 - 95% relative humidity (non-condensing)
Sample Pressure	By external overflow vessel (open to atmospheric pressure)
Sample Flow Rate	100 - 300 mL/min
Power	100 - 240 VAC, 50/60 Hz Max. power consumption: 120 VA
Instrument Air	Dry and oil free according to ISA-S7.0.01-1996 quality standard for instrument air. Used to flush the instrument in corrosive environment. Min. 0.2 bar - Max. 0.5 bar
Drain	Atmospheric pressure, vented, min. Ø 32 mm
Earth Connection	Earth connection Dry and clean earth pole with low impedance (< 1 Ohm) using an earth cable of > 2.5 mm ²
Analog Outputs	Active 0 - 20 mA (or 4 - 20 mA) max. 500 Ohm load, standard 4, optional: 8
Digital Outputs	Relays: 5 contacts, not user configurable: Malfunction, maintenance, analysis ready, sample ready, sample ready (EZ9150) Ethernet Connections: Optional: Claros Ethernet connection and Modbus TCP/IP Ethernet connector; LAN version; 10/100 Mbps or Profinet or Ethernet IP RS485 communication: Profibus DP or Modbus RTU
Protection Class	IP44
Material	Hinged part: Thermoform ABS, Door: PMMA Wall section: Galvanized steel, powder coated
Dimensions (H x W x D)	688 mm x 460 mm x 340 mm
Weight	Max. 77 lb (35 kg)
Certifications	CE, ETL certified to UL and CSA safety standards, UKCA

*Subject to change without notice.

Dimensions

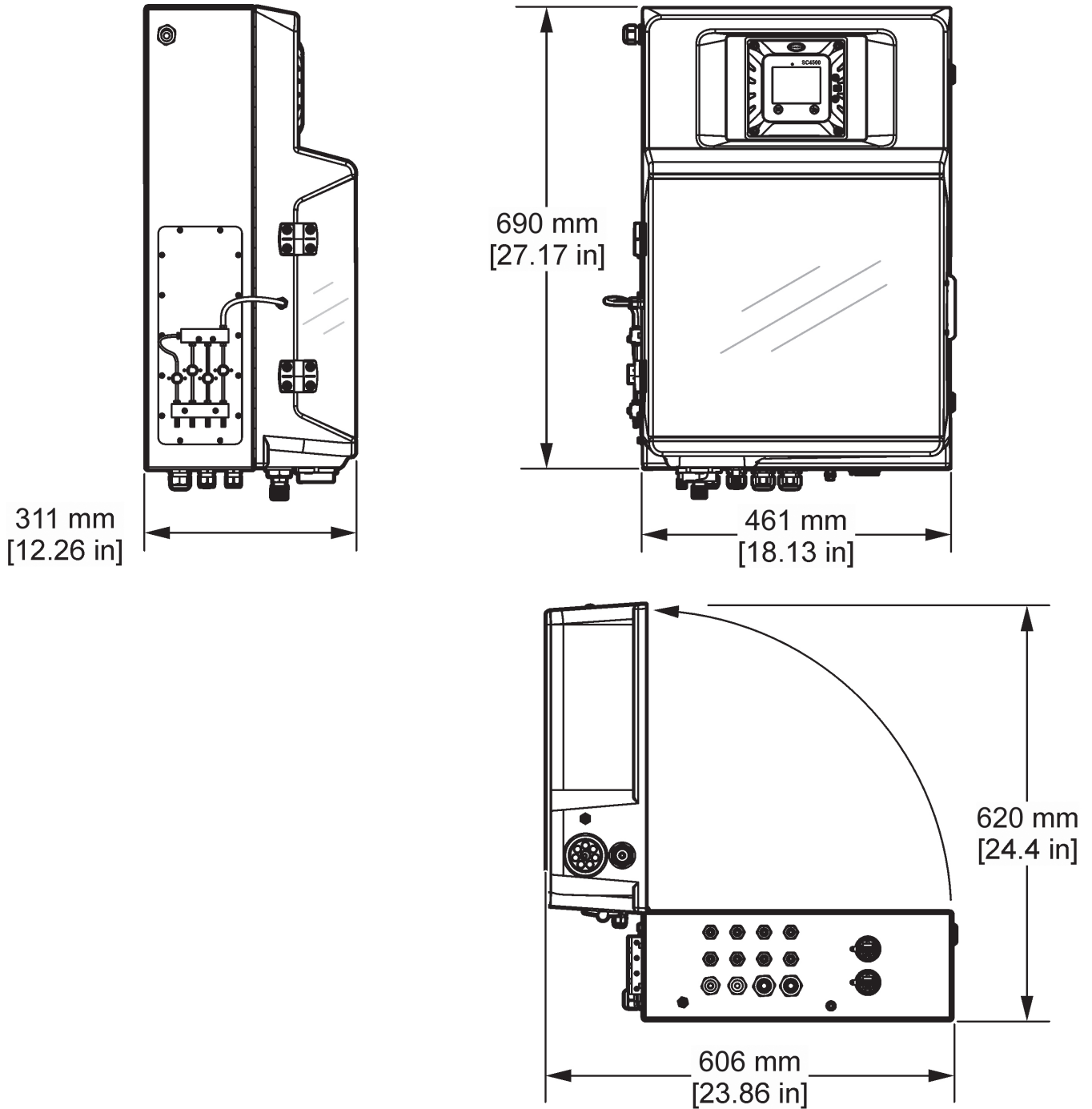

Enable the Benefits of Smart Monitoring

This instrument connects to Claros, Hach's innovative Water Intelligence System. Claros allows you to seamlessly connect and manage instruments, data, and process – anywhere, anytime. The result is greater confidence in your data and improved efficiencies in your operations. To unlock the full potential of Claros, insist on Claros Enabled instruments.

Hach Service Protects Your Investment

With Hach Service, you have a global partner who understands your needs and cares about delivering timely, high-quality service you can trust. Our Service Team brings unique expertise to help you maximize instrument uptime, ensure data integrity, maintain operational stability, and reduce compliance risk.

Order Information

EZ3005.97	X	X	X	X	X
Measurement range					
2 - 100 mg/L Cl ⁻	0				
5 - 250 mg/L Cl ⁻					
10 - 500 mg/L Cl ⁻					
20 - 1000 mg/L Cl ⁻					
Power supply					
100 - 240 VAC, 50/60 Hz		0			
Number of sample streams					
1 stream			1		
Outputs					
4x mA				4	
8x mA				8	
4x mA + Modbus RTU				D	
8x mA + Modbus RTU				E	
4x mA + Modbus TCP/IP				I	
8x mA + Modbus TCP/IP				J	
4x mA + Profinet				N	
8x mA + Profinet				O	
4x mA + Profibus DP				S	
8x mA + Profibus DP				T	
4x mA + Ethernet/IP				X	
8x mA + Ethernet/IP				Y	
No adaption, "SC4500" version					0T

Accessories

APPAZ0080002 - Moduplex, 2 streams, Pinch Valve, 1/8" OD

APPAZ0080004 - Moduplex, 4 streams, Pinch Valve, 1/8" OD

APPAZ0080008 - Moduplex, 8 streams, Pinch Valve, 1/8" OD

